

SURFACE FITTINGS

16W 2D GOLF HIGH FREQUENCY FITTING

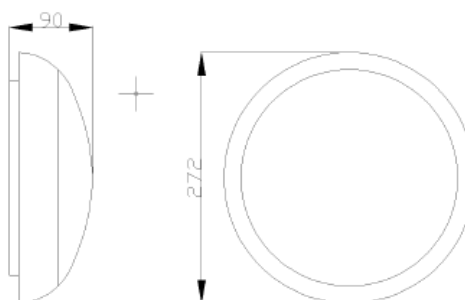

R162D+L-01HF	White
R162D+L-02HF	Brass
R162D+L-03HF	Chrome
Diameter(mm):	272
Depth(mm):	90
Box Qty:	6
Weight (Kg):	1.18kg
Max W (W):	16W
Cap Type:	GR8
IP:	65
Guarantee:	2



For all building types this unique wall or ceiling mounted fitting provides a clean modern design where a pleasing profile is important. It is available in a range of trims providing a great looking fitting combined with the latest energy efficient technology. Applications include:

- Commercial buildings
- Stairways
- "Back of house" areas
- Health centres
- Sports centres
- Retail shops
- Corridors
- Public buildings
- Apartment communal areas

FEATURES	BENEFITS
<ul style="list-style-type: none"> • Polycarbonate opal diffuser and body 	<ul style="list-style-type: none"> • Strong, durable and impact resistant • Less susceptible to damage • Vandal resistant • UV stabilised so will not degrade
<ul style="list-style-type: none"> • Complete with 2D, 16W, 4pin lamp 	<ul style="list-style-type: none"> • 12,000 hour lamp life, up to 10 times that of a standard incandescent lamp so fewer lamp changes required
<ul style="list-style-type: none"> • Colour 3500K 	<ul style="list-style-type: none"> • Light colour close to that of natural light gives a comfortable working environment • Saving 80% energy compared to incandescent sources
<ul style="list-style-type: none"> • High Frequency electronic control gear 	<ul style="list-style-type: none"> • Flicker-free start and running provides almost instant light for safety and working environment • Extends lamp life by approx 50% compared to switch start • Saving up to 50% energy compared to switch start
<ul style="list-style-type: none"> • Twist lock trim 	<ul style="list-style-type: none"> • Easy lamp change (no tools required)
<ul style="list-style-type: none"> • Available in 3 trims, white, brass, & chrome 	<ul style="list-style-type: none"> • Choice of finishes to suit decor
<ul style="list-style-type: none"> • IP65 	<ul style="list-style-type: none"> • Suitable for indoor & outdoor use
<ul style="list-style-type: none"> • 2 year guarantee 	<ul style="list-style-type: none"> • A quality energy efficient long life product

PLEASE NOTE – INFORMATION CONTAINED IN THIS DOCUMENT IS SUBJECT TO CHANGE WITHOUT PRIOR NOTICE