

## PANEL SOCKET WITH ANGLED MOUNTING PLATE 32A IP44 - UIS432-6S



32A 5Pole - 3Pole + N + E

Operating Voltage - 230 - 400V  
 Frequency - 50/60Hz  
 Clock Position, colour code - 6 ■

For panel mounting  
 Connectable Cable Size 2, 5-6 mm<sup>2</sup> and 2, 5-10mm<sup>2</sup> for solid cable  
 Degree of protection IP44.

### PRODUCT MEASUREMENTS

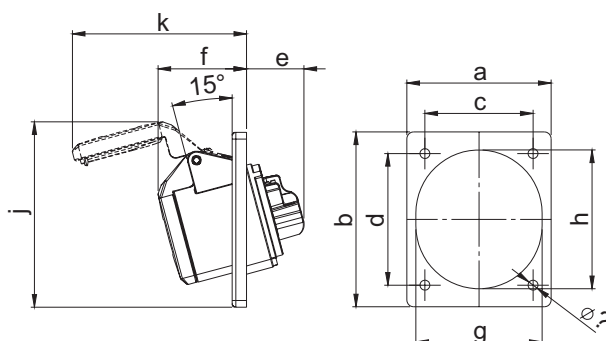

In	Poles	a	b	c	d	e	f	g	h	i	j	k	Weight
32A	5	80	97	60	73	48	55	70	80	5,5	110	125	0,250Kg

Our IEC/CEE connectors are now tested and certified under the international standard IEC 60 309, which has been developed in the IEC standardisation organisation (International Electrotechnical Commission). This worldwide standard is systematically applied to all GARO products. The use of this standard eliminates the possibility of incorrect connections, regardless of the circumstances.

The standardised products are colour-coded according to a clock face, where the clock positions (1 to 12) correspond to the earth socket position in the socket, viewed from the front, with the locating groove always at the 6 o'clock position. Each position corresponds to a voltage and frequency value of each 2, 3 and 4 pole socket with rated currents of 16A, 32A, 63A and 125A and voltages of >50V to 690V.



GARO plugs and sockets are tested and certified and comply with the following international and national standards, among others:

IEC 60 309-2, IEC 60 309-1, SS EN 60309-1, SS EN 60309-2, CEE17, SEMKO 117, VDE 0623, BS 4343, EN 50 250