

ETS TH TWIN SPOT



Lamp Options

- 2 x 20 watt luminaire to provide 2 x 300 lumens for 3 hour duration.
- Lamp colour - 5000K.
- LED indication of correct charger function.
- LED indication of lamp filament function.

Materials

- Body - powder coated sheet steel.
- LED projectors - flame retardant ABS plastic.
- Batteries (self-contained) - 2 x SLA 12V 7.0Ah.

Installation notes

- Suitable for high level wall mounting.
- 20mm cable entry on side of unit.
- 20mm cable entry on rear of unit.
- Dimensions 305mm L x 70mm D x 306mm H.
- Supplied complete with TH lamp source.

Colours



The ETS twin spot (ETS) range of luminaires have been specifically designed to provide a cost effective and low maintenance emergency lighting solution in high bay industrial areas, factories or large warehouses where there is a requirement to project high intensity beams between the racks and equipment to illuminate walkways and assist safe evacuation in case of emergency.

- Competitively priced, tungsten halogen twin spot.
- Easy to install and maintain.
- Available in self-contained versions.
- Swivel and tilt mounting TH projectors.
- IP20 as standard.
- Supplied with TH projector lamp.
- 2 year warranty.

Options

- 230V +/-10% 50/60Hz.
- Non-Maintained 3 hour duration .
- Colours - White RAL 9016.
- Class I.

Specification

Self-contained - to specify state the following

IP20 Tungsten Halogen self-contained emergency twin spot projector suitable for wall mounting with swivel and tilt mounting Tungsten Halogen projectors. Complete with charge LED indicator and independent lamp continuity indicators as the ETS twin spot range.

Part Number _____

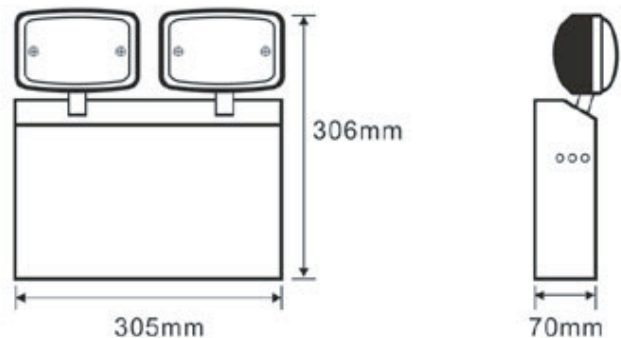

Catalogue Numbers

System Mode	Part Number	Weight (kg)
Non-Maintained 3 hour - white	ETS20/NM3	6.4



VENTILUX UNIT 2, ASHGROVE INDUSTRIAL ESTATE, KILL AVENUE, DUN LAOGHAIRE, COUNTY DUBLIN, IRELAND
 TEL +353 (0)1 214 8800 FAX +353 (0)1 280 5729 E-MAIL sales@ventilux.ie www.ventilux.ie

VENTILUX

VENTILUX UK, ARBOUR COURT, ARBOUR LANE, KNOWSLEY IND EST, LIVERPOOL L33 7XE, UNITED KINGDOM
 TEL +44 (0)151 546 4155 FAX +44 (0)151 546 3987 E-MAIL sales@ventilux.co.uk www.ventilux.co.uk