

# EVBox Iqon

EVBox Iqon is the award-winning 22 kW AC charging station that provides reliable and accessible charging for all commercial locations.



reddot award 2019



# Meet EVBox Iqon

Built for commercial locations that aim to offer customers reliable EV charging with a premium look and feel.

## Accessible charging for everyone

- Ergonomic cables
- Intuitive 8" touchscreen
- Wheelchair accessible

## Manage stations with peace of mind

- Easy to install and maintain
- Suitable for indoor and outdoor use

## Scale easily and earn revenue quickly

- Always connected
- Commercialize your Iqon stations



### IDEAL FOR



Retail



Hospitality



Commercial  
parking



Charging  
service  
providers



Real  
estate



Workplace



Car fleets



Transit and  
transport



Cable is locked until user starts charging session.

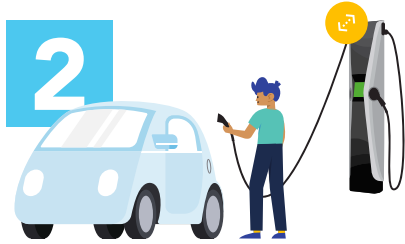

Cable unlocks so that user can plug it into the car.



During charging, the cable is locked to the car.

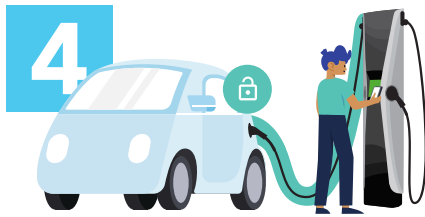

User stops the session, cable unlocks.







User inserts cable into station, cable is locked.

# What makes EVBox Iqon **more accessible** than other stations?

Equipped with a **unique, auto-retractable cable system**, EVBox Iqon's cables are easy to handle by all users while keeping charging cables safely off the ground.

The locking plug holders and multi-language touchscreen are placed at a height that's **easily accessible to all users, whether standing or in a wheelchair**. With a premium, multiple award-winning design, EVBox Iqon guarantees your visitors and customers a seamless charging experience.

## ACCESSIBLE CHARGING FOR EVERYONE

-  **Smart cable management** with a 5.5 m weighted auto-retractable cable
-  **LCD touchscreen** that's 8" and multi-language
-  **Wheelchair accessible**, weatherproof, and shockproof
-  **Two cars** can charge up to 22 kW simultaneously
-  **Universally compatible** with any electric car with a Type 2 connector

# How do I **manage multiple Iqon stations** with peace of mind?

Link up to 10 Iqon stations via the **Hub-Satellite configuration** to enable load balancing, which ensures that the available power supply is distributed efficiently between all connected vehicles.

**Dynamic load balancing** adds another layer of safety by enabling communication between the site's energy meter and the stations. This reduces stress on the grid by adjusting how much energy can be used for EV charging in realtime.



## LOAD BALANCING

You can set a maximum current for your charging network, and the stations will consume the allotted power responsibly.

Every 15 minutes, the Hub charger evaluates the charging status of every car. It will then place the car that has charged the most in a queue and start charging the car that has charged the least.

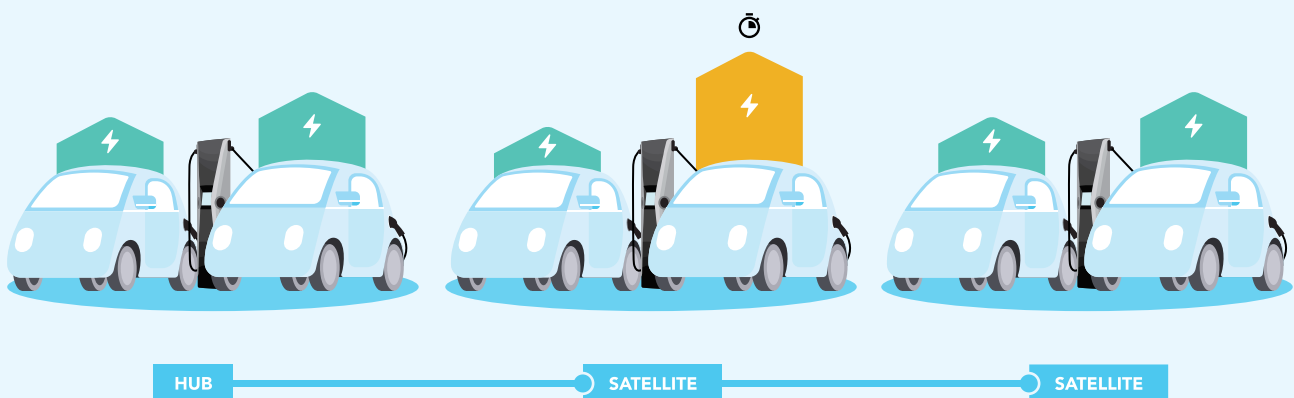

## DYNAMIC LOAD BALANCING

Your stations consume the available power flexibly based on supply and demand.

If additional on-site facilities (e.g. A/C or fridges) are consuming less power, **your stations can charge at a higher power.**

If additional on-site facilities are consuming more power, **your stations can charge using less power.**

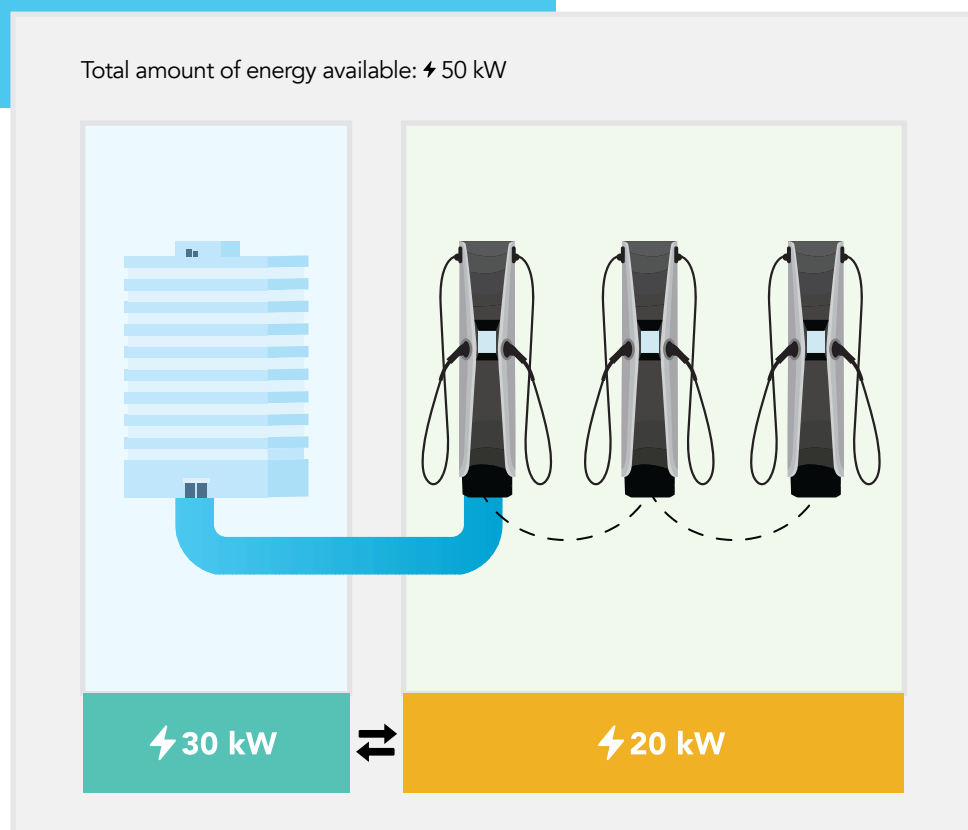

## CHARGERS THAT GIVE YOU PEACE OF MIND



**Wi-Fi and 4G** to receive firmware updates and undergo maintenance remotely



**Modular design** ensures easy installation, service, and maintenance



**Built-in electrical protections** including RCBO and DC leakage detection



**3-year warranty** with an option to extend to five years



**Weatherproof and shockproof** for all locations



**Charges up to 8 times faster** than a regular outlet





# How can I **earn revenue** with my stations?



Earn your investment back and create an additional revenue stream by publishing your station to a public charging map and **setting a tariff** for charging sessions. Meanwhile, you can easily **manage invoices and reimburse** the relevant charging transactions with your EVBox Iqon users.



## SCALE EASILY AND EARN REVENUE QUICKLY

-  **Publishing your stations** on a public charging map
-  **Set custom charging fees** for charging sessions
-  **OCPP-compliant** making it compatible with all charging management systems
-  **Tracks, schedules, invoices, and reimburses** charging transactions
-  **Track, schedule, invoice, and reimburse** charging transactions easily

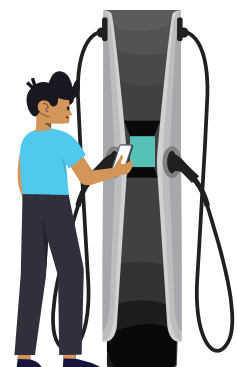

**EV DRIVER**

# Technical specifications

## ELECTRICAL OUTPUT

<b>Max. charging capacity</b>	Up to 22 kW per cable
<b>Charge mode</b>	Mode 3 (IEC 61851) / Level 2 (UL2594)
<b>Output power (dual 32 A input)</b>	2x 22 kW (3-phase, 230–400 V AC, 32 A per cable)

## PHYSICAL PROPERTIES

<b>Dimensions, mm (W x H x D)</b>	415 x 1894 x 275 mm with 50 mm removable base extension
<b>Weight</b>	80 kg (excluding packaging)
<b>Mounting</b>	Ground mount (free standing, wall-supported or back-to-back)
<b>Housing</b>	Stainless steel
<b>Plastic materials</b>	UL 94 – V0 / US-FMVSS / ISO 3795 passed, DIN 53438 F1/K1

## SAFETY AND CONNECTIVITY

<b>Electrical safety</b>	Integrated RCBO 16 A or 32 A for 30 mA AC leakage detection per outlet / CCID 6 mA DC leakage detection per outlet
<b>Station surge protection</b>	6 kV
<b>Maximum cluster size</b>	10 dual chargers (20 connectors)
<b>Mobile connectivity - Hub</b>	4G LTE-FDD CAT1 (B1/3/7/8/20) / 3G WCDMA (Band 1/8) / GSM (900/1800 Mhz)
<b>Connectivity - Hub</b>	Dual band Wi-Fi 2.4/5 GHz, Bluetooth 4.0 for configuration with the EVBox Connect app, GPS
<b>Time synchronization - Hub</b>	GPS / Wi-Fi
<b>Communication protocol - Hub</b>	OCPP 1.5 S / 1.6 S / 1.6 J
<b>Enclosure rating</b>	IEC 60529 / IP54 / IK10 / UL 50E (Type 3R)
<b>Collision detection</b>	Tilt sensor

## INTERFACES

<b>Connectors</b>	2x Type 2 (IEC 62196-2) cables
<b>Charging cable length</b>	5.5 m with smart cable management system
<b>Plug holders</b>	With docking sensor and locking mechanism
<b>Display</b>	8" (20 cm) LCD IPS full color screen (768 x 1024 px) with capacitive touch, sunlight readable
<b>Display languages</b>	English, Spanish, French, German, Dutch
<b>System lighting</b>	Day/night mode, auto-adjustable light intensity, automatic system wake-up
<b>Session activation</b>	RFID / QR code

<b>Operating temperature</b>	-30°C to +50°C
<b>Operating humidity</b>	85% @ 50°C (non-condensing)
<b>Storage temperature</b>	-40°C to +60°C
<b>Storage humidity</b>	95% @ 50°C (non-condensing)
<b>Safety and compliance</b>	IEC 61851-1 (2017), IEC 61851-21-2 (2018), IEC 61000-3-2 (2014), IEC 61000-3-3 (2013), EN 301 489-1 V2.2.0, EN 301 489-3 V2.1.1, EN 301 489-17 V3.2.0, EN 301 489-52 V1.1.0, EN 301 908-1 V11.1.1, EN 301 511 V12.5.1, EN 300 330 V2.1.1, EN 300 328 V2.1.1, EN 301 893 V2.1.1, EN 300 220-1 V3.1.1, EN 300 220-2 V3.1.1, CE conformity, RoHS, REACH
<b>Metering</b>	S-Bus MID certified class B
<b>Smart energy management</b>	Adjusting max. current, charging profiles, dynamic load balancing (via MAX protocol)

# Technical specifications

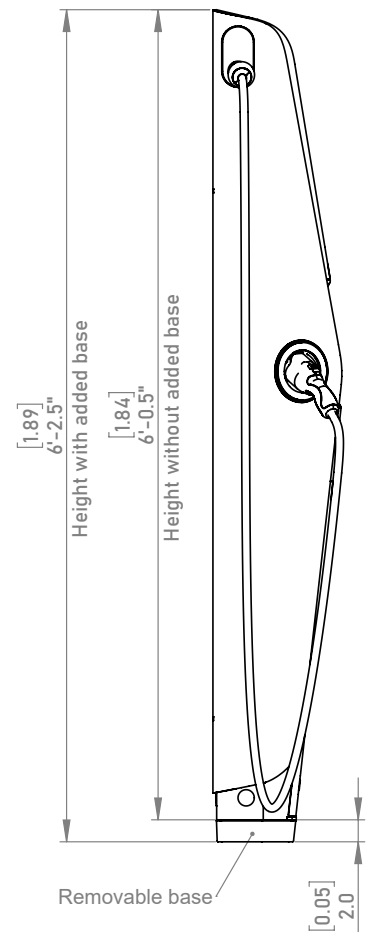
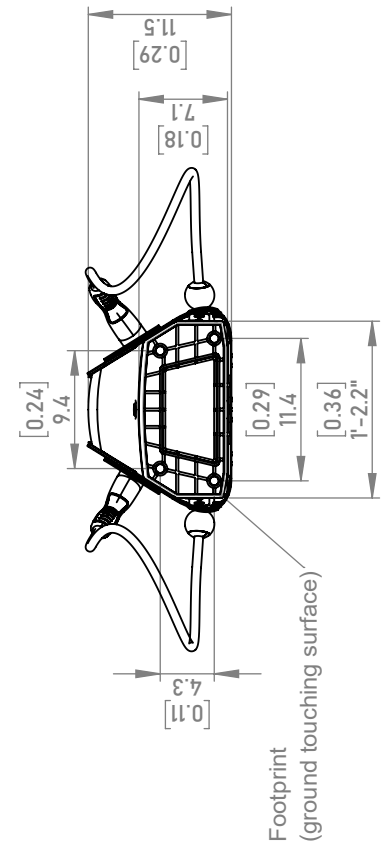
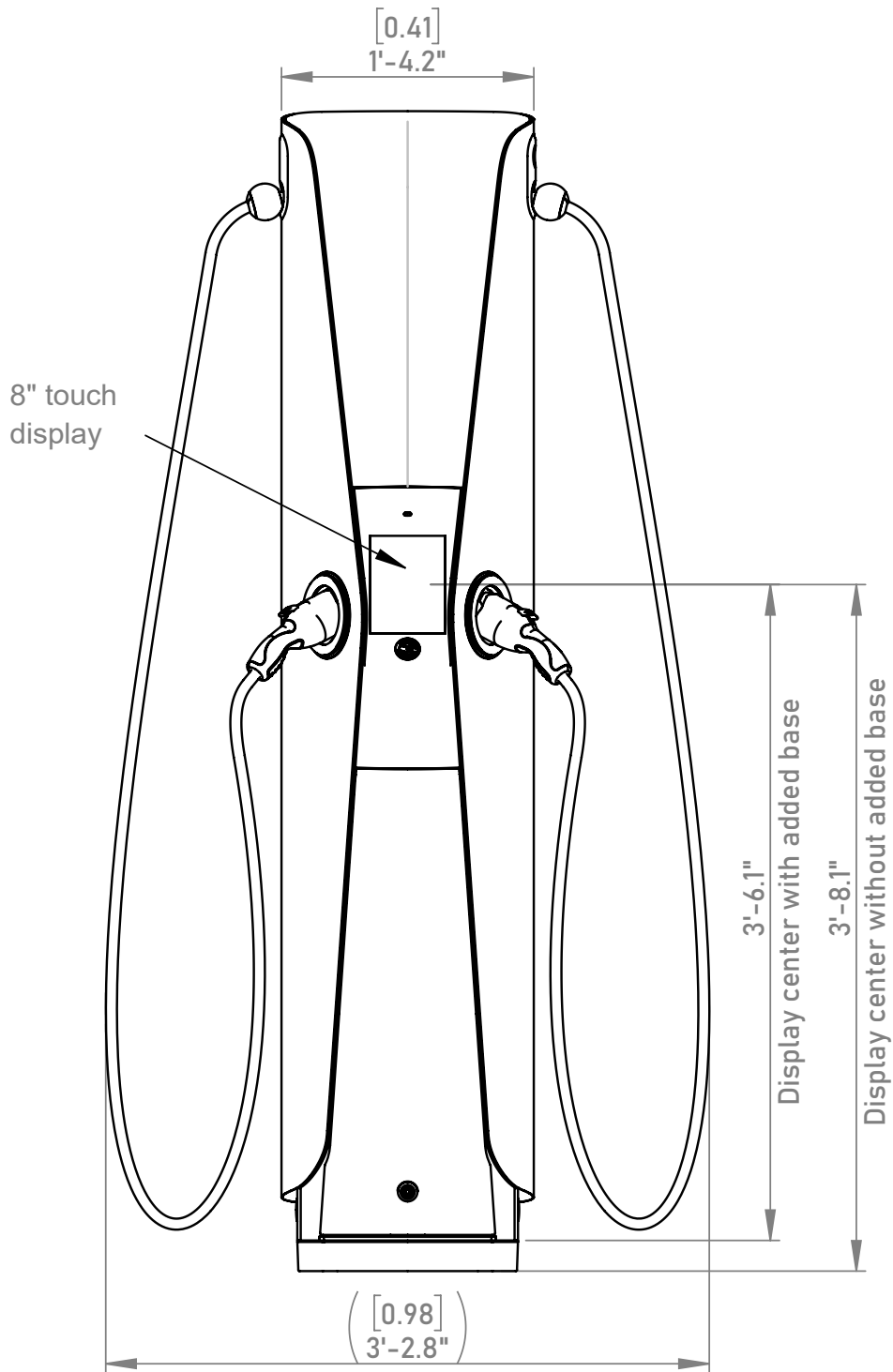



# Get started with EVBox



## TELL US YOUR PREFERENCES

Enter your preferences in this short online form [evbox.com/quote](https://evbox.com/quote).  
It's free and takes just two minutes!



## GET YOUR FREE QUOTE

We'll give you a call to discuss your needs and provide you with  
a commitment-free price estimation.



## TECHNICAL VISIT

Upon approval, our technicians will inspect your site and power capacity  
to determine your final installation plan and price.



## INSTALLATION

Our highly-skilled and certified installers will safely set up your new station  
at the optimal location on your site.



## MAINTENANCE & SUPPORT

Alongside our partners, we provide you with ongoing maintenance and support.  
We're available 24/7 online and via phone.

Get started today at [evbox.com/quote](https://evbox.com/quote)



Download the manual at [evbox.com/manuals](https://evbox.com/manuals)

Copyright © 2020 EVBox Manufacturing B.V. Elvi®, EVBox® and the EVBox logo are registered trademarks. All rights reserved. EVBox has compiled this document to the best of its knowledge but does not warrant that all information provided is error-free; EVBox does not accept liability in that respect. All specifications are approximates only. The limited warranty conditions are stated in the applicable EVBox general terms and conditions. EVBPI\_ELVI\_EN\_052020 © EVBox Manufacturing B.V.

EVBox Manufacturing B.V., Kabelweg 47, 1014 BA, Amsterdam, The Netherlands, [evbox.com/support](https://evbox.com/support)